

PERFORMANCE DATA



H140 EC
High Efficiency
For Open Ceilings Up To 140ft

FAN SPECIFICATIONS

Test results for H140-EC Premium Efficiency Fan using the 208-277V motor with guard grill on suction side and air guide installed.

- H140-EC Premium Efficiency EC Motor
- 208-277V 50/60Hz 560 watts 2.7A
- 1440 RPM
- Multi-Functional air guide on exhaust side
- Finger Guard Grill on suction side

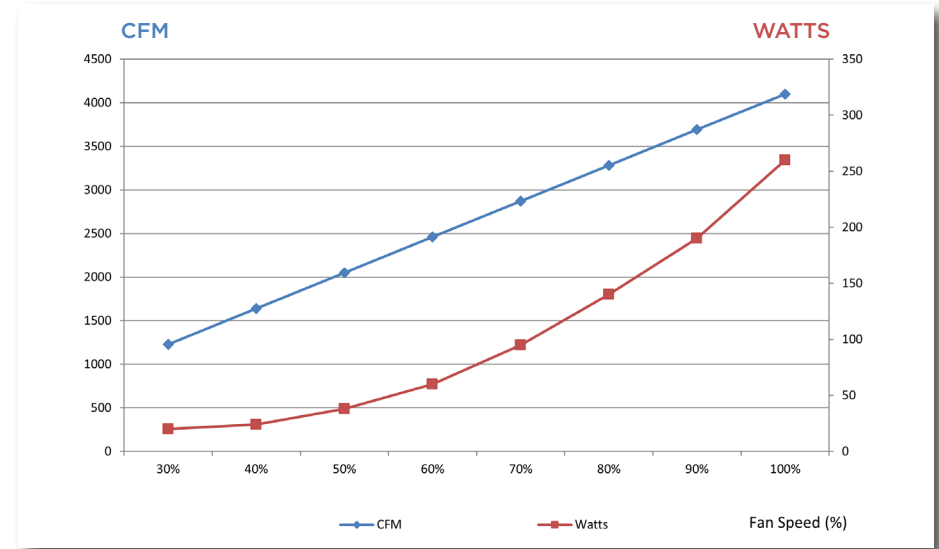

DATA TABLE

Fan Speed	Control Signal (V)	CFM	RPM	Watts	Amps	Sound Power (LwA6)
100%	10	5400	1440	560	2.7	77
90%	9	4860	1300	434	2.1	74
80%	8	4320	1150	294	1.4	71
70%	7	3780	1010	210	1.0	68
60%	6	3240	860	140	0.68	64
50%	5	2700	720	91	0.44	62
40%	4	2160	580	56	0.27	58
30%	3	1620	430	42	0.20	54

Feet per Minute

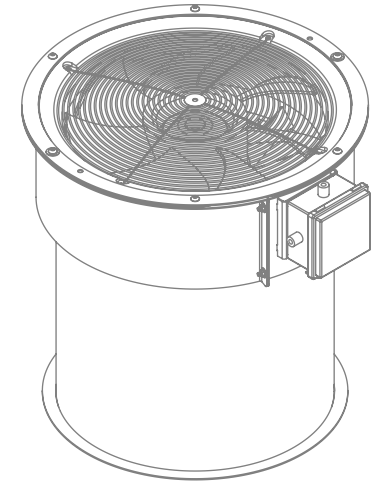
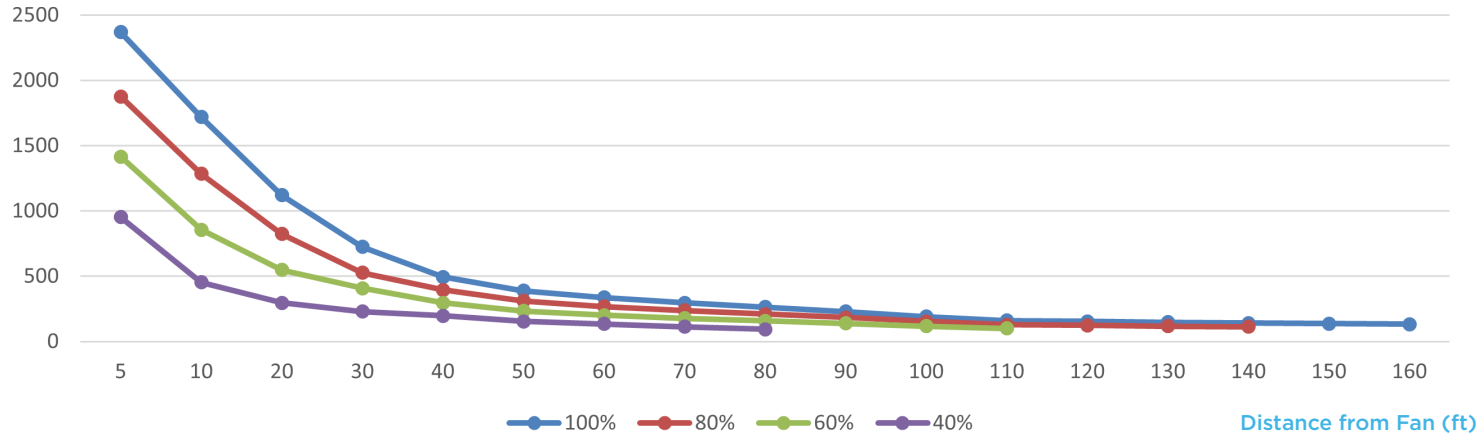

100% Fan Speed	
Distance from fan (ft)	Air Speed (ft/min)
5	2370
10	1719
20	1120
30	724
40	494
50	389
60	336
70	296
80	263
90	230
100	191
110	160
120	154
130	148
140	142
150	137
160	133

80% Fan Speed	
Distance from fan (ft)	Air Speed (ft/min)
5	1877
10	1284
20	823
30	527
40	395
50	311
60	269
70	237
80	211
90	184
100	153
110	129
120	123
130	118
140	114

60% Fan Speed	
Distance from fan (ft)	Air Speed (ft/min)
5	1416
10	856
20	547
30	408
40	296
50	233
60	202
70	178
80	158
90	138
100	118
110	101

40% Fan Speed	
Distance from fan (ft)	Air Speed (ft/min)
5	952
10	454
20	296
30	230
40	198
50	155
60	134
70	114
80	94